

# CENTRAL ASIAN JOURNAL OF THEORETICAL AND APPLIED SCIENCES

Volume: 03 Issue: 09 | Sep 2022 ISSN: 2660-5317

<https://cajotas.centralasianstudies.org>

## The Development Strategy of Fishing Fisheries (Katsuwonus Pelamis Linneus) in Tomini Bay, Gorontalo Province

**Syamsuddin, Lis M Yapanto**

Water Resources Management Gotontalo State University  
syamsuddin@ung.ac.id, lizrossler@ung.ac.id

**Achmar Mallawa**

Faculty of Fisheries and Marine Affairs, Hasanuddin University Makassar

*Received 9<sup>th</sup> Jul 2022, Accepted 10<sup>th</sup> Aug 2022, Online 12<sup>th</sup> Sep 2022*

**Abstract:** *Development Strategy of Skipjack Catch Fishery (Katsuwonus Pelamis Linneus) In Tomini Bay, Gorontalo Province. This study aims to analyze the development strategy technology for skipjack tuna (Katsuwonus Pelamis Linneus). This research was carried out from March 2021 to September 2021 in the waters of Tomini Bay, Gorontalo Province. Data were collected through observational surveys, interviews and questionnaires to determine the fishing strategy by conducting a PRA (Participatory Rural Appraisal) survey with SWOT and AHP analysis. The results of this study indicate that the priority strategies that can be implemented are (1) Development of facilities and infrastructure that support sustainable and environmentally friendly capture fisheries production; (2) Improving the quality of Human Resources to support efforts to utilize fishery resources in a sustainable manner; and (3) Procurement of database.*

**Keywords:** *Tomini Bay, Skipjack, Capture Fisheries Strategy.*

### I. Introduction

Geographically, Gorontalo Province is located at 0019' – 1015 North Latitude and 123o43' – 123o43'E. The position of this province is in the northern part of the island of Sulawesi, which is directly adjacent to the Province of North Sulawesi in the east and Central Sulawesi Province in the west, while in the north it is directly facing the Sulawesi Sea and in the south with Tomini Bay which is deep sea waters. deep-sea waters).

Overall, Gorontalo Province has an area of 12,215.44 km<sup>2</sup>, which consists of (1) Boalemo Regency covering an area of 2,248.24 km<sup>2</sup> (18.4%), (2) Gorontalo Regency covering an area of 2,248.24 km<sup>2</sup>. 3,226.98 km<sup>2</sup> (28.05%), (3) Pohuwato Regency covering an area of 4,491.03 km<sup>2</sup> (36.77%), (4) Regency

Bone Bolango covering an area of 1,984.40 km<sup>2</sup> (16.25%), (5) North Gorontalo Regency covering an area of 1,230.07 km<sup>2</sup> (10.07%), and (6) Gorontalo City covering an area of 64.79 km<sup>2</sup> (0.53%). 226,090 tons/year (19.15% of the potential of marine fisheries throughout Indonesia) with a new utilization rate of around 28.22 %. This potential also includes the potential of Tomini Bay of 293,830 tons/year, so that the fishery sector has not yet been fully explored (Department of Fisheries and Marine Affairs of Gorontalo Province, 2020).

One of the efforts that can be done to answer this is through community fisheries management with the development of appropriate fishing technology. This effort should be operationally aimed at achieving sustainable balanced catches, production that economically provides maximum sustainable profit, and optimal social conditions such as maximizing labor and reducing conflicts between fishermen.

The phenomenon of the utilization of fishery resources that occurs today in Gorontalo Province is dominated by fishermen with small-scale fishing businesses. Most of the existing fishing tools and methods are traditional and are cultivated based on hereditary habits. Conditions that take place without development efforts based on bio-technical and socio-economic studies will cause the majority of fishing communities to remain in economic backwardness and inability to develop businesses.

The existence of pressure and damage is quite high, especially the utilization of fishery resources using irresponsible fishing gear, if this is allowed to continue, it is feared that it will experience extinction in the future.

Utilization of fishery resources, especially capture fisheries, has not made a real contribution to development. The production of the catch is still low, the diversity of fishing gear is still low, management management is not optimal and the use of fishing gear is not environmentally friendly. For this reason, it is necessary to have policies that can increase the contribution of capture fisheries to development, especially improving the welfare of fishing communities. Therefore, it is necessary to conduct research to examine strategies for developing sustainable and environmentally friendly skipjack tuna fisheries in Tomini Bay, Gorontalo province.

## II. Research Methods

### 1. Research Time and Location

This research was carried out from March 2021 to October 2021 at the base of fishing communities who catch fish around the waters of Tomini Bay, Gorontalo Province.

### 2. Research Materials and Tools

This study uses tools and materials as presented in Tables 1 and 2.

**Table 1. The equipment used in the study.**

No.	Equipment and Specifications	Utility
1.	GPS (Global Positioning System)	Determining the position of the catchment area fish
2.	Digital camera	Taking research pictures
3.	Ruler	Measuring fish length
4.	Stationery writing	Record research data
5.	Bucket	Taking water samples
6.	Questionnaire	a list of questions
7.	Boat	Transportation

8.	Thermometer, Refractometer, pH Meters, DO Meters	Determine parameter Quality Water waters
9.	Fishing Equipment Units (fishing rods, nets, traps, etc.)	Means of Sampling

**Table 2. Materials used in the study**

No.	Equipment and Specifications	Utility
1.	Fish	Measure length, weight, (cm)
2.	Aquades	Cleaning tools
3.	Formalin	Preserving fish
4.	Satellite Image Data	Determination of fishing grounds

### 3. Research methods

Based on the objectives to be achieved, this research was carried out using a survey research method approach to the research object (Stakeholders, fishermen, fisheries actors & aquatic biota) in the waters of Tomini Bay, Gorontalo Province. Especially for information from fishermen, it is equipped with a list of questions so that the information obtained is more focused on the core of the problem. In addition, he also directly participates in fishing operations to find out and clarify data related to operational techniques in the field.

As for the survey of fishing areas, a plot system is carried out based on geographical position. The data collected in determining fishing strategies and priorities, conducted a PRA (Participatory Rural Appraisal) survey, by digging as much community-based information as possible; government and private. This is done to obtain a solution for developing fishing gear that is in accordance with the wishes of capture fisheries stakeholders. Based on the results of this PRA survey, an AWOT analysis was then carried out (Rangkuti, 2003).

### 4. Data analysis

Development strategy analysis was carried out in a quantitative descriptive manner using the SWOT method. The SWOT method is a means of systematically identifying various variables based on logic that can maximize strengths and opportunities, but at the same time minimize weaknesses and threats. For the weighting of each SWOT factor, Comparative Judgment uses the Analytical Hierarchy Process (AHP) method. AHP is a measurement method used to find the ratio scale of both discrete and continuous pair comparisons. These comparisons can be taken from actual measures or from a basic scale that reflects the strength of relative preferences.

In general, the main objective is to determine a sustainable fishing development strategy (sustainable). Based on these objectives, the research variables were arranged using multi-attribute analysis, which is an analytical tool used to break down large and complex decisions into smaller and measurable variables.

These variables are SWOT strategic factors that can be measured by assigning a value, the strategic factor is the level of frequency/magnitude of these factors in capture fisheries management compared to other factors.

SWOT analysis is an analytical method that produces alternative strategies or policies that are carried out in a decision making.

The stages of the SWOT analysis used in the A WOT analysis are carried out by collecting all information that affects management and development, both externally and internally. Data collection is also a classification and pre-analysis activity. External factors are opportunities (opportunities) and threats (Treaths) management and development of capture fisheries. The internal factors are Strengths and Weaknesses.

The weighting system on the comparison scale in the analysis between criteria uses a comparison scale guide table (saaty, 1993). This scoring system is based on the relative importance of one criterion compared to other criteria (Table 3).

After determining the criteria mentioned above, an analysis is carried out based on the results of research and interviews conducted with fishermen community leaders in the field. The criteria that are considered not problematic means that they meet environmentally friendly fisheries. Furthermore, the problematic criteria are then given several alternative solutions and then analyzed through Hierarchical Process Analysis (saaty, 1993).

**Table 3. Comparison scale in pairs based on relative importance**

<b>Intensity of Importance</b>	<b>Definition</b>	<b>Explanation</b>
<b>1</b>	Both elements are equally important	Two elements have the same great influence on the goal
<b>3</b>	One element is slightly more important than the other elements	Experience and judgment slightly favor one element over the other.
<b>5</b>	One element is essential or very important compared to other elements	Experience and assessment is very strong support one element compared to other elements.
<b>7</b>	One element is clearly more important than the other elements	An element is strongly supported and its dominance has been seen in practice
<b>9</b>	One element is absolutely more important than the other elements	Evidence in favor of one element against another has the highest possible level of affirmation to corroborate
<b>2, 4, 6, 8</b>	Values Among two score close consideration	This value is given when there are two compromises between the two choices
<b>opposite</b>	If for activity I gets one point when compared to activity j, then j has the opposite value when compared to i	

### III. Results and Discussion

#### A. Capture Technology

The technology used in the utilization of fishing resources for skipjack, mackerel, kite and tuna is adapted to the nature and behavior of the target fish. Anchovies, Tuna (*Thunnus spp.*), Selar, Cob, skipjack

(Katsuwonus pelamis), Tail Kuing, Kuwe, Mackerel, Squid, and others are fish that often flock. Therefore, the fishing gear used must be in accordance with the behavior of the fish. There are several types of fishing gear used by fishermen, including:

### 1. Hand Line/Tuna Longline

Hand line is a fishing line that is given a long line and pulled by a boat or boat (Figure 1). The fishing line is baited with fresh fish or fake bait which due to the influence of the pull moves in the water so as to stimulate wild fish to grab it.

#### a. Fishing Equipment and Fishing Vessel

In principle, the fishing line used consists of a long rope, a fishing line without a ballast. This fishing rod generally uses artificial bait / fake bait. The artificial bait can be made of chicken feathers, attractive colored fabrics or plastic materials in miniature to resemble the real thing (eg squid, fish, etc.).



**Figure 1. Line Fishing Unit**

The fishing line construction consists of a string reel, a fishing line, a swivel, a ballast or without a ballast and a fishing rod. Hand line consists of important components, namely:

- a) Main rope ( monofilament number 1000) with a main rope length of about 150 - 300 m;
- b) Branch rope (monofilament number 800) with rope lengths ranging from 15 cm – 225 cm;
- c) Fishing line Nos 6, 7 and 8;
- d) Fresh bait and fake bait made of silk fabric;
- e) A buoy made of cork;
- f) swivel made of tin and ballast;

The ships used are of medium scale, with an average length of 7.3m – 12.5 m, depth 0.75 m – 2.75 m, and width 1.35 m – 1.5 m, and an average ship tonnage 5 – 25 GT. The material for this boat is usually meranti wood. The type of machine used is an outboard motor with an average power of 15 PK, and the number of workers is usually only 3-5 people.

## b. Catch

The main catches for surface water handlines are tuna, skipjack, mackerel, yellowfin tuna, setuhuk, pestle, sunglir, several types of kuwe. The catch in the deep layer is mainly squid, while the bottom layer is mainly catfish, stingray, cucut, gulamah, sukain, grouper, and others (Subani & Barus, 1989).

The types of fish that are the target of catching include bonito fish (*Scomberomeros* sp.), tuna, salmon, skipjack, mackerel, and others through the back or side of the ship that moves not too fast, a number of fishing lines are pulled with eyes. fishing rods that are generally hidden in artificial baits. The fish will hunt and catch the artificial baits, this of course allows them to be caught.

## 2. Purse Seine Unit

### a. Fishing Equipment and Fishing Vessel

Purse seine is a tool (gear) used to catch pelagic fish that form schools. Purse seine was first used in Rhode Island waters to catch menhaden fish (*brevortia tyrannus*). Furthermore, the purse seine was patented in the name of Berent Velder from Bergen in Norway on March 12, 1859. By 1860, this tool had been used all over the Atlantic coast and the United States. Then in 1870, the length of the purse seine was changed from 65 fathoms to 250 fathoms (1 fathom = 1,825 m). It was from this form that the purse seine was introduced to Scandinavian countries in the same year (Uktolseja in Rahardjo, 1978).

The principle of catching fish with a purse seine is to circle the school of fish with a net, so that the net forms a vertical wall, thus preventing the movement of fish in a horizontal direction. After that, the bottom of the net is tapered to prevent the fish from running towards the bottom of the net.

Ring trawlers are operated by wrapping a net around schools of fish. The loop is done quickly, then immediately pulls the purse line between the existing rings, so that the net will form like a bowl. High speed is required in this case so that the fish cannot escape. After the fish are in the net bowl, then the catch is taken using a scoop or scoop.

The ring seine can be operated during the day as well as at night. The operation of ring seines during the day often uses FADs or payaos as fishing aids. Fish collection tools that are often used in the operation of ring trawlers at night are lights, generally using a petromax lamp.

The coastal areas of Kwandang Port and Gentumana Raya are fishing base areas as well as fishing ports for Lampara/Mini Purse Seine vessels in the waters of the Sulawesi Sea with specifications as shown in (Figure 2). These activities include: preparation before the ship departs, the method of catching and handling the catch.



Figure 2. Purse Seine Ship Unit

### c. Catch Handling

After the hauling is complete, the crew of the ship (ABK) immediately handle the catch which includes: (1) This washing is intended to clean the blood and dirt from the body of the fish. This is done by spraying pressurized seawater which is driven by a generator engine and also manually by flushing with seawater; (2) The selection of fish here is to separate the fish by type. During the study, there were more than 10 types of fish caught, namely: bloated, tembang, peperek, anchovies, squid, machetes, skipjack tuna (*Katsuwomts pelamis*), yellowfin tuna (*Thunnus albacares*) and tuna (*Euthynnus affinis*); (3) Storage of fish during fishing operations using wooden hatches and baskets. At first, the bottom of the hatch is given enough crushed ice. The fish are stacked on top of the ice in sufficient quantities, then the top is covered with a layer of ice again evenly; and (4) Unloading is carried out after the ship arrives at the port or TPI and is deposited with the ship owner. The fish are removed and hatched or baskets and put into plastic baskets for further marketing.

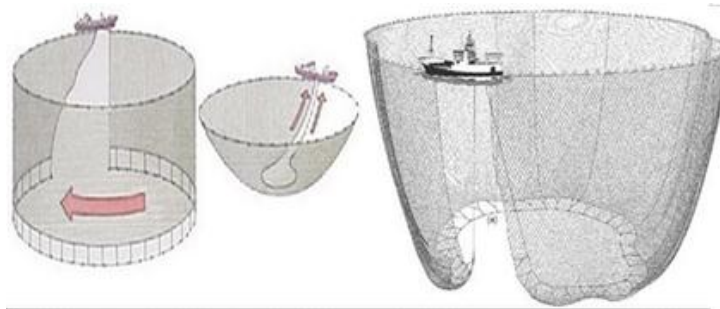

**Figure 3. Mini Purse Seine Setting Process**

### 3. Payang/Lampara

Payang fishing gear is a modified fishing gear that resembles a small trawl that is operated on the surface of the waters. In terms of construction, the fishing gear is almost similar to the lampara, the difference is that the otter board is not used in its operation. Payang operations are carried out on the surface layer of the waters. Payang has a low level of selectivity, due to the use of a small mesh size, so it can catch small fish, such as anchovies to larger fish, such as tuna and so on. Payang fishing gear at the study site is widely operated with small vessels (less than 30 GT) with a limited number of trips (generally one day fishing). Payang is economically a profitable fishing tool because it produces fish with high economic value (anchovy rice) and can also catch large fish such as tuna, mackerel and so on. The operation begins with lowering or spreading the net, then continues with the withdrawal of the net, until finally the fish are collected and the net is then lifted. Next the fish will be taken and put into the hold.

#### a. Description of Payang Catcher

Ayodhya (1981) states that the payang net fishing gear consists of rope, legs, body and bag. The working principle of the payang net is to catch fish around FADs using nets that have pockets. To operate the payang net, a boat with a size of 12.0 mx 2.4 mx 1.0 m is used. As the driving force used Panther engine with the power of 4 cylinders (1 PK).

According to Sudirman and Mallawa (2004), payang fishing gear is made of nylon multifilament synthetic fiber. Overall net length varies from tens of meters to hundreds of meters. Based on the classification from FAO, this fishing gear is classified as a circular net. The structure of this fishing gear is as follows:

- a. Wings: Payang has two wings, namely the left wing and the right wing. The construction of the upper and lower parts of the wings differs in size and material from which these wings are made of PA material.
- b. The body consists of 6 parts, namely:
  - ✓ The bag (cod end) is a gathering place for netted fish.
  - ✓ The top rope (Head Rope) serves as a place to tie the wings of the net, the body of the net (the upper lip) and the buoy.
  - ✓ The bottom rope (Ground Rope) serves as a place to tie the wingsnets, net body parts (lower lip) nets and weights.
  - ✓ Towing pull (sheet) Functionto pull the net during operation.
  - ✓ Buoy (float): The general purpose of using a buoy is to provide buoyancy to cantrang fishing gear which is attached to the upper ris line (top lip of the net) so that the mouth of the net can be opened.
  - ✓ Weight (Sinker): mounted on the bottom ris rope with the aim that the partsThe part that is fitted with this ballast sinks quickly and stays in its position (bottom of the water) even though it is under the influence of the current.

#### b. Payang's Catch

The catches obtained with the payang fishing gear are pelagic fish that swim near the surface of the water in groups (schooling) such as tuna, skipjack, tuna, petek (*Leiognathus* spp), side (*Psettodidae*), and types of shrimp (*Shrimp*). . (Come on, 1981). The catch from Payang consists of various types of fish that are commonly used as bait, such as: scad fish (*Decapterus* sp), kawalnya fish (*Rastrelliger* sp), sardines (*Sardinella* sp), anchovy (*Stelophorus* sp), and stray fish (*Caesio*). sp (Subani Barus, 1989).

#### 4. Handline Fishing Unit

Handline fishing gear (Handline) is usually operated to catch pelagic fish that have high economic value and have many names such as “Pancing Pemesan”, “Klewer Fishing Line”, “Tunda Cap”, “Irid Fishing Line”, “Land Line”. diluent”, “fishing FADs” and many other regional names.

A tug line is a fishing line that is attached to a long line and pulled by a boat or boat (Figure 4). The fishing line is baited with fresh fish or fake bait which, due to the influence of the pull, moves in the water so that it stimulates wild fish to grab it.

##### a. Fishing Equipment and Fishing Vessel

In principle, the fishing line used consists of a long rope, a fishing line without a ballast. This fishing rod generally uses artificial bait / fake bait. The artificial bait can be made of chicken feathers, attractive colored fabrics or plastic materials in miniature to resemble the real thing (eg squid, fish, etc.).



Figure 4. Fishing Rod Unit



The construction of the tug line consists of a string reel, fishing line, swivel, ballast or without ballast and fishing line. The tug line consists of important components, namely (Figure 5):

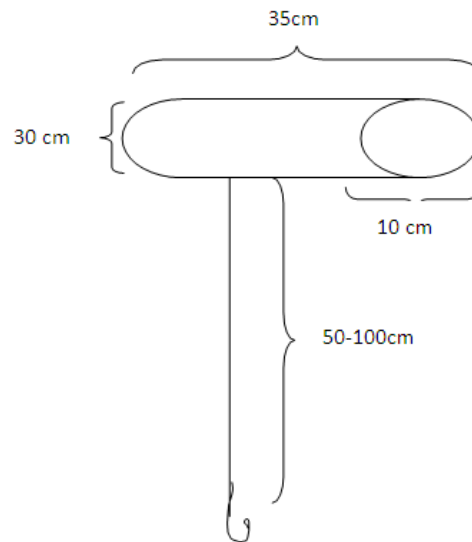

**Figure 5. Construction of the Toddler Fishing Tool**

Information:

- ✓ The buoy, which is used for fishing rods in the Palabuhanratu area, is in the form of a drum or conductor. The size of the drum that is widely used by fishermen is 35 x 10 x 25 cm. The use of this buoy is only limited as a roller when the fishing rod is not operated.
- ✓ The main rope used by tug line fishermen is usually made of nylon. The length of the main rope commonly used by trolling fishermen in the Palabuhanratu area is 50 – 70 meters, depending on the depth of the waters of the fishing area, and the diameter of the main rope is 2 mm. Meanwhile, in one setting, the trolling fisherman can operate 1 – 8 trolling lines.
- ✓ The ballast used for the tow line fishing gear is made of tin or cement. The number of ballast used for one unit of fishing line is one weighing 1 kg or 40 ounces.
- ✓ The hooks used for tug fishing are made of stainless or steel. The number of hooks used by trolling fishermen in Palabuhanratu varies between numbers 1 – 7. The number of hooks is determined based on the type of fish to be caught. For example, to catch tuna species, you usually use hook number 6.

The construction of the tugboat is made of wood. The wheelhouse is located at the stern, the engine room is in the middle, at the top of the wheelhouse there is the crew room, the fish hatch is located at the bow. The tugboats are about 3-20 GT in size, made of teak (*Tektona grandis*) and ironwood (*Eusiderrixylon* spp.). The dimensions of the ship are length (LOA) 10.75-12 meters (m), width (B) 2.85-3.50 meters (m), height (D) 1-1.5 meters (m). The tugboat uses an inboard engine, with a power of about 20-40 HP.

#### **b. Catch**

The main catches for surface waters are tuna, skipjack tuna, mackerel, yellowfin tuna, setuhuk, pestle, sunglir, several types of kuwe. The catch in the deep layer is mainly squid, while the bottom layer is mainly catfish, stingray, cucut, gulamah, gladin, grouper, and others (Subani & Barus, 1989). The types of

fish that are the target of catching include bonito fish (*Scomberomeros* sp.), tuna, salmon, skipjack, mackerel, and others through the back or side of the ship that moves not too fast, a number of fishing lines are pulled with eyes. fishing rods that are generally hidden in artificial baits. The fish will hunt and catch these artificial baits, this of course allows them to be caught (Gunarso, 1998).

**E. Strategy for the Utilization of Skipjack Catch Fish**

Determination of capture fisheries development strategies, especially skipjack tuna fisheries in Tomini Bay Waters, Gorontalo Province, is carried out using SWOT analysis. According to Rangkuti (2003), this analysis is based on a logic that can maximize strengths and opportunities, but simultaneously minimizes Weaknesses and Threats, which is carried out in the form of a matrix. The results of the identification of internal and external factors carried out on The development of skipjack tuna capture fisheries shows the relative comparison of the influence of one factor on other factors according to the respondents (Table 4).

**Table 4. SWOT Analysis of Capture Fisheries Development**

<p>Internal</p>	<p>Strength :</p> <ul style="list-style-type: none"> <li>➤ Potential of fishery resources</li> <li>➤ There are inter-departmental programs related to the management of fishery resources</li> <li>➤ There are human resources</li> <li>➤ The existence of supporting infrastructure for program development empowermentcoastal community</li> <li>➤ Existence technologyfishing and catch handling</li> <li>➤ Marketing system</li> <li>➤ The existence of an institutional system</li> </ul>	<p>Weakness:</p> <ul style="list-style-type: none"> <li>➤ Weak capital support for fishermen/coastal communities</li> <li>➤ Lack of meansinfrastructure</li> <li>➤ The lack of experts/technical assistants who master fishing technology and handling of catches</li> <li>➤ The quality of human resources is still low</li> <li>➤ Weak group institutions fisherman/coastal community</li> <li>➤ Market information is not smooth</li> </ul>
<p>External</p> <p>Opportunity</p> <ul style="list-style-type: none"> <li>➤ High untapped fishery potential</li> <li>➤ The existence of technology for catching and handling catches whichrelatively simple (can still be mastered by fishermen)</li> </ul>	<p>Strategy 1</p> <ul style="list-style-type: none"> <li>➤ Combining strength and opportunity</li> <li>➤ Increase potencyavailable fishery</li> <li>➤ Develop the use of capture and handling technology</li> <li>➤ Expand networkcatch marketing</li> </ul>	<p>Strategy 2</p> <ul style="list-style-type: none"> <li>➤ Develop a capital system</li> <li>➤ Developing a fishing business</li> <li>➤ Developing fishery infrastructure</li> <li>➤ Improving the quality of human resources and fishery apparatus</li> <li>➤ Develop and build systemadministrative and institutional capacity</li> </ul>

<ul style="list-style-type: none"> <li>➤ Source catch marketing prospects powerfishery</li> <li>➤ Increasing demand for fishery products</li> </ul>		<ul style="list-style-type: none"> <li>➤ Develop marketing and market information services</li> </ul>
<ul style="list-style-type: none"> <li>➤ Export market demand for fishery commodities</li> <li>➤ Existence programand policygovernment center,area which cansupport andincrease fishing activities</li> <li>➤ Existence innovationtechnology</li> </ul>		
<p><b>Threat</b></p> <ul style="list-style-type: none"> <li>➤ Existence activitysource capture power the fishery no</li> <li>➤ Friendlyenvironme nt and environmental impact</li> <li>➤ Risk natural(waves, waves, damage to the aquatic environment)</li> <li>➤ Technical risk</li> <li>➤ Market risk (price during low fishing season.</li> </ul>	<p><b>Strategy 3</b></p> <ul style="list-style-type: none"> <li>➤ Increase productionoptimal and environmentally friendly capture of fishery resources</li> <li>➤ Develop a planning, evaluation and monitoring system</li> <li>➤ Develop rehabilitation and protection of fishery resources</li> <li>➤ Increase networkdistribution of fishery products</li> <li>➤ Increase systeminstitutional</li> </ul>	<p><b>Strategy 4</b></p> <ul style="list-style-type: none"> <li>➤ To do activityfishing resources byresponsible and environmentally friendly as well as onscience and technology-based development</li> </ul>

Based on the SWOT analysis above, several alternative strategies for developing fishing community empowerment policies can be obtained to overcome weaknesses and threats. The alternative strategies

are:

1. Combining strength and opportunity
2. Increase the potential of available fisheriesm
3. Develop the use of capture and handling technology
4. Expanding the catch marketing network
5. Develop a capital system
6. Developing fishery resources business
7. Developing fishery infrastructure
8. Improving the quality of human resources and fishery apparatus
9. Develop and foster an administrative system and institutional capacity
10. Develop marketing and market information services
11. Increase environmental productivity
12. Develop a planning, evaluation and monitoring system
13. Develop rehabilitation and protection of aquaculture resources
14. Improving the distribution network of catches of fishery resources
15. Improve institutional system
16. Carry out fishing activities in a responsible and environmentally friendly manner and oriented towards science and technology-based development

Based on the analysis of the policy strategy that has been formulated, a development strategy is drawn up. The main objective is to make the coastal area as a center of economic development through the management and utilization of fishery resources to improve the welfare of the community.

The strategy for developing an activity program to improve the economic standard of living of fishing communities in North Gorontalo Regency is a reference in the planning process for the management and utilization of fishery resource potential. Therefore, in formulating a development strategy for the empowerment of fishing communities, it is necessary to consider various aspects related to development models, including: aspects of natural resources and the environment, economic aspects (access to national and international markets), aspects of improving facilities and infrastructure and social and institutional aspects. .

Several strategy formulations in the development of activity programs to improve the economic standard of living of fishing communities in North Gorontalo Regency, namely:

### **1. Natural Resources Development**

- a) Integrated management and utilization of resources as an effort to maintain, improve, and improve the quality of coastal and marine resources.
- b) Development and utilization of appropriate and environmentally friendly technology to improve the quality of fishery and marine resources.

- c) Identify various other natural resource utilization activities that are not environmentally friendly and damage natural resources in coastal and ocean areas.
- d) Develop various technologies for utilizing natural resources that are environmentally friendly and do not damage the natural resources of coastal and ocean areas.
- e) Development of appropriate and environmentally friendly fishery product handling and processing technology.

## **2. Economic Development**

- a) Development of market distribution systems, both nationally and internationally oriented
- b) Development of superior commodity products, especially the fishery sector and increasing the variety of goods and services commodities that are channeled and transacted cross-regionally.
- c) Increased investment in the construction of infrastructure for transportation of goods and people.
- d) Increasing the efficiency of the distribution system and allocation of resources by reducing the relative cost of using transportation and communication services (cost and time).
- e) Increased volume of flows and transactions of goods and services.

Development of an adequate development investment system through promotion, application of incentives and disincentives as well as development of capital infrastructure that supports the development of small and medium enterprises.

## **3. Human Resources and Institutional Capacity Development**

- a) Development of human resource capacity in the management of coastal and marine resources.
- b) Development of educational facilities and systems.
- c) Revitalization of traditional and local institutions in the regions to actively participate in the management of coastal and marine resources, especially in the implementation of regional autonomy.
- d) Strengthening institutions at the government level in managing coastal and marine resources across sectors and regions in the context of regional autonomy.
- e) Development of policies that prevent the occurrence of a monopolistic/oligopolistic system in a vertically integrated agribusiness chain.

## **IV. Conclusions and Recommendations**

### **Conclusion**

Strategies that can be developed for skipjack tuna fishing in Tomini Bay are: (1) Development of facilities and infrastructure that supports sustainable and environmentally friendly capture fisheries production; (2) Improving the quality of Human Resources to support efforts to utilize fishery resources in a sustainable manner; and (3) Procurement of database.

### **Suggestion**

1. Because the potential for MSY, MEY and OSY of skipjack tuna has not been exceeded (overfishing), it is necessary to pay special attention to avoid extinction of skipjack tuna resources, including by limiting the area and time of fishing;

2. In catching skipjack tuna, fishermen should use the fishing area map issued by the Department of Fisheries and Marine Affairs.

## References

1. Anggraeni, Resky N., Safruddin and M. Zainuddin. 2014. Spatial and Temporal Analysis of Skipjack Catches (*Katsuwonus pelamis*) and the thermal front in the transitional season in the waters of Bone Bay. *Science and Technology Journal of Fisheries Resource Utilization, FIKP Unhas*. Vol.1 (1): 20 - 27.
2. Arimoto, T., 1999. Research and Education System of Fishing Technology in Japan. The 3rd JSPS International Seminar. Sustainable Fishing Technology in Asia toward the 21st century. P32-37.
3. Ayodhya, AU, 1972. Craft and Gear. Correspondence Course Centre. Jakarta. 86 p. Charles, AT, 1994. Towards Sustainable. The Fishery Experience. *Ecological economics*, 11; 2001-211.
4. Charles, AT, 2001. Sustainable Fishery Systems. Blackwell Science. London. 370p.
5. Dahuri, RJ, Ginting, SP, and Sitepu, MJ, 1996. Integrated Management of Coastal and Ocean Resources. PT. Pradnya Paramita. Jakarta. 305 p.
6. Ministry of Marine Affairs and Fisheries. 2003. Recent Developments in Indonesia's Marine and Fisheries Development Policies and Programs. DKP RI, Jakarta. 63 p.
7. Gorontalo Province Fisheries & Marine Service, 2020. Statistics of the Gorontalo Province Fisheries Annual Report.
8. FAO. 1999. Fisheries Statistics – Primary Product 1998. <http://apps.fao.org/lim500/nhp-warp.pl?Fisheries>. Primary and Domain = SUA.
9. Fisher, WL 2007. Recent trend in fisheries geographic information system. In GIS/ Spatial Analyses in Fishery and Aquatic Sciences (Vol.3). Fishery-Aquatic GIS research group, Saitama, Japan. 488p.
10. Gunarso, W. 1985. Fish Behavior in Relation to Fishing Methods and Tactics. *Jur. Utilization of Fisheries Resources Fak. Fisheries IPB, Bogor*. 143 p.
11. Haluan, J., and Nuraeni, TW, 1988. Application of the Scoring Method in Selection of Appropriate Fishing Technology to be Developed in a Water Area. PSP Department Bulletin, IPB Bogor, Volume II, No. 1; 3 – 16.
12. Mallawa, Najamuddin and Zainuddin, M., 2018. Analysis of Fisheries Potential Development in Selayar District, South Sulawesi Province. Makassar.
13. Masyhuri and Zainuddin, M., 2008. Research Methodology. Practical and Applicative Approach. Publisher PT. Aditama Refika. Bandung. 234 p.
15. Monintja, DR, 1994. Development of Capture Fisheries with Environmental Perspective. Paper Presented at the Seminar on the Development of Environmentally Friendly Fisheries Agribusiness at the Fisheries College. Jakarta. 12 pp.
16. Monintja, DR, 2000. Training Proceedings for Integrated Coastal Area Management Trainers.
17. Center for the Study of Coastal and Ocean Resources. Bogor Agricultural University, Bogor. 156 pp.

18. Monintja, Daniel R. and Roza Yusfiandayani, 2000. Utilization of Coastal and Sea for Capture Fisheries Activities. Training Materials for Trainers in Integrated Coastal Area Management. Wave II. PKSPL – IPB. Bogor. 13 – 18 November 2000.
19. Najamuddin, 2004. A Study on the Utilization of Sustainable Fish Resources (*Decapterus* spp.) in Makassar Strait Waters. Dissertation. Postgraduate Program in Agricultural Systems Study Program, Hasanuddin University. Makassar.
20. Purbayanto, A., and Baskoro. 1999. A Brief Overview of the Development of Environmentally Friendly Fishing Technology. Mini Review on the Development of Environmental Friendly Fishing Technology. Graduate Student at Tokyo University of Fisheries. Dept. of Marine Science and Technology, Tokyo. 5 p.
21. Rangkuti, F., 2003. SWOT Analysis of Business Case Dissecting Techniques. Reorientation of Strategic Planning Concepts to Facing the 21st Century. PT. Gramedia Pustaka Utama, Jakarta. 188 p.
22. Saaty, TL, 1993. Taking Decision. For Leaders. PT Pustaka Binaman Pressindi. Jakarta. 270 p.
23. Safruddin, M. Zainuddin and J. Tresnati. 2014. The dynamics of changes in temperature and chlorophyll-a on the distribution of anchovy (*Stelophorus* spp) in the coastal waters of Spermonde, Pangkep. Science and Technology Journal of Fisheries Resource Utilization. FIKP Unhas. Vol.1 (1): 11 -19.
24. Zainuddin, M., AFP Nelwan, A. Farhum, MAI Hajar, Najamuddin, M. Kurnia and Sudirman. 2013. Characterizing Potential Fishing Zone of Skipjack Tuna during the Southeast Monsoon in the Bone Bay-Flores Sea Using Remotely Sensed Oceanographic Data. International Journal of Geosciences, Vol. 4: 259-266.
25. Shabbir, MS, Siddiqi, AF, Yapanto, LM, Tonkov, EE, Poltarykhin, AL, Pilyugina, AV, Petrov, AM, Foroughi, A., & Valiullina, DA (2021). Closed-loop supply chain design and pricing in competitive conditions by considering the variable value of return products using the whale optimization algorithm. Sustainability (Switzerland), 13(12), 1–17.<https://doi.org/10.3390/su13126663>
26. Yapanto, LM, Harahab, N., Sudarto, & Olli, AH (2021). Feasibility test of fishing variables on increasing fishermen's income in tomini Bay, Gorontalo province. ARPN Journal of Engineering and Applied Sciences, 16(17), 1777–1784. <https://doi.org/10.31219/osf.io/yvjez>
27. Yapanto, LM, & Nursinar, S. (nd). Traditional Handline Fishing in Pohuwato Regency , Indonesia. 6, 24–30.